

Development of automatic repair technology by continuous and quick mixing technology

Junichi Tsukuda, Youichi Furuta, Hiroyuki Itoh, Kazunori Seki

Seiji Hanagiri^a, Takayuki Uchida^a, Satoru Itoh^a, Seiji Asoh^a

Sakae Nakai^b

ABSTRACT

In conventional wet-gunning it is not easy to decrease the amount of water in the gunning mix because the mix has to be pressurized and transported smoothly through hoses. An excessive amount of water in the mix often results in a poor durability of the body of gunned material. The newly developed method, Continuous Quick Mixing & Repairing Technology (QMS), does not require the gunning mix to be transported through hoses and therefore, the amount of water can be decreased. As a result the installed body, obtained by means of the QMS method, has a more excellent quality when compared to the wet-gunning method. Furthermore the cleaning job after the gunning repair is as easy and simple as that after dry-gunning. This paper describes the development of QMS and the improved durability of the gunned material.

1. PREFACE

The conventional gunning application of refractory materials has been performed in various ladles and furnaces and classified as dry-gunning and wet-gunning. The former is easier and simpler from the point of view of application, but a much greater amount of water is required in the gunning mix, which often results in poor durability of the gunned material body. The latter is effective to obtain a relatively dense gunned body, but gunning work is not simple due to the preliminary mixing and to the cleaning of equipment after work. Continuous Quick Mixing & Repairing Technology (QMS as the abbreviation of Quick Mixing Shot) is introduced in this paper. It provides both a simpler and easier gunning method equivalent to that in conventional dry-gunning and a more excellent quality of the gunned body which results in better durability than that obtained in conventional wet-gunning.

2. FEATURES OF THE GUNNING EQUIPMENT

2.1 Conventional gunning methods

Fig. 1 shows the typical conventional gunning methods: dry-gunning and wet-gunning. In dry-gunning dry refractory material is conveyed by air flow and gunning water is added at the tip of the nozzle to produce slurry which is subsequently applied. In wet-gunning the

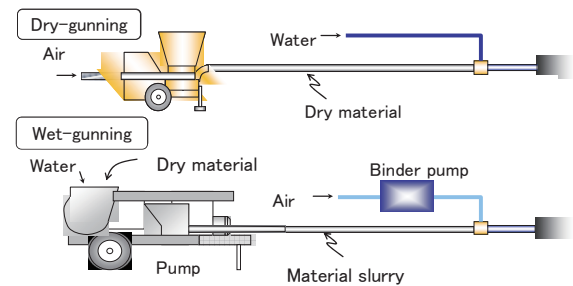

Fig. 1 Conventional gunning methods

material is mixed first with water to produce slurry which is pressurized and conveyed through hoses and mixed with binder at the tip of the nozzle in order to solidify the gunned body.

2.2 Features and advantages of the QMS method

1) The system of the QMS method

Fig. 2 shows the system of the QMS method, which consists of a material feeder, a water pump, a binder pump and the Continuous Quick Mixing & Repairing device. Refractory material is conveyed by air flow and water is sprayed¹⁾, as fine mist, into it just before the device. Next the mix of material and water is kneaded in the mixing chamber to obtain an excellent kneading effect.

After kneading, the gunning mix is flung to the targeted repair spot by a rotating projection disk. In the QMS method, the material after having been mixed with water is not conveyed through hoses. Therefore, the amount of water can be reduced considerably.

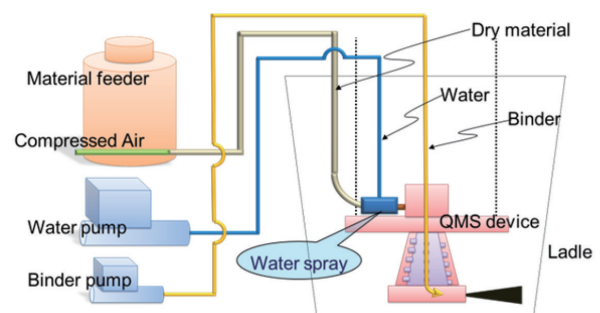

Fig. 2 Application system of the QMS method

^a : Nippon Steel & Sumitomo Metal Corporation

^b : NS engineering Corporation

2) The Continuous Quick Mixing device

Fig. 3 shows the vertical section of the Continuous Quick Mixing device. In the fixed outer casing the inner rotor is installed and rotates with 800 min^{-1} . The upper half of the rotor has many dispersion blades on its cylindrical surface, while the lower half is conical and has many kneading pins on its conical surface. The blades and pins are positioned along the spiral line on the rotor surface. The outer rotor, which covers the conical surface of the inner rotor, rotates with 150 min^{-1} . Dry material is sprayed with water¹⁾ and fed horizontally close to the top of the outer casing. After having been mixed by the dispersion blades in the upper half of the inner rotor, the mix descends to the lower half and forms there the relatively dense retention layer due to the centrifugal force generated by the rotation of the outer rotor. As shown in **Fig. 4**, the retention layer is scratched by many kneading pins on the inner rotor. When scratched, the retention layer of the mix is subjected to shearing, compression and tensile forces and deformed and kneaded sufficiently. The scratching does not occur at the same height but on the different levels of each kneading pin, due to the spiral positioning of the kneading pins. The kneaded mix is gradually pushed downward along the inner surface of the outer rotor to the projection disk.

3) Principle and mechanical structure of the gunning device

The kneaded mix is conveyed and gunned to the targeted repair spot not by means of conventional compressed air but by centrifugal flinging force. As shown in **Fig. 5**, the gunning device consists of 1) the projection disk positioned at the lower exit of the outer rotor, 2) the belt wound around the disk (with one opening area) to drive it and 3) the reflector to direct and rectify the mix flow toward the spot of application. The adhesion of the kneaded mix on the targeted repair spot can be optimized by adjusting appropriately both the velocity of the mix flow and the thickness of the gunned material body.

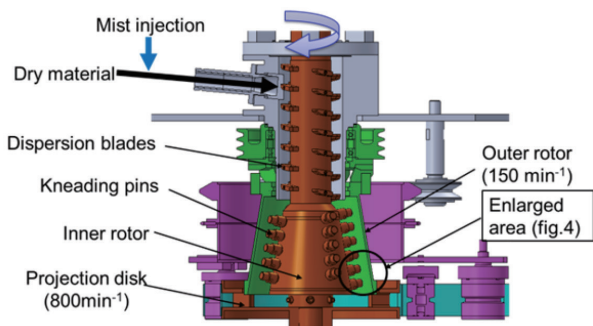

Fig. 3 Mechanical structure of the continuous quick mixing device

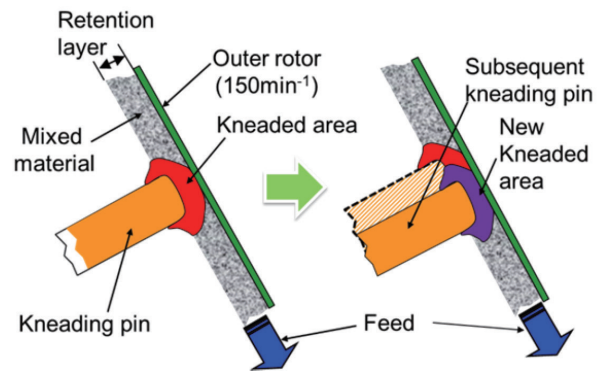

Fig. 4 Principle of kneading

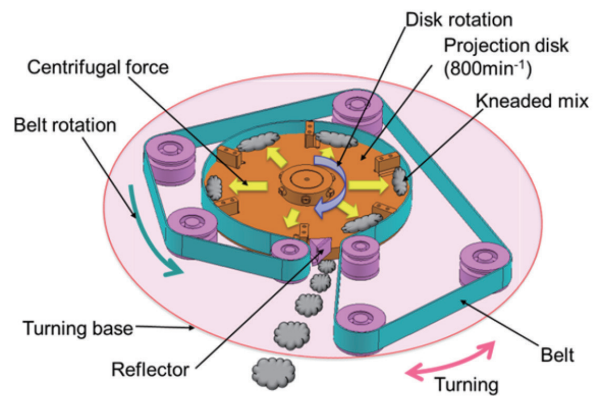

Fig. 5 Plane view of the gunning device and isometric view of the projection disc

3. EVALUATION OF THE MIXING EFFECT

To evaluate the mixing effect, the QMS was compared with a common desk-top mixer in mixing for three minutes. After adding a specified amount of water, the material was mixed with the continuous quick mixer and also with the desk-top mixer for three minutes and the viscosity of the mixed material was measured in each case. The kneading ratio is defined as the value determined by dividing the viscosity of the material mixed by the QMS device with that mixed by the desk-top mixer. As shown in **Fig. 6**, the QMS device showed 89 % of kneading ratio under the mixing condition of a 15 mm gap between the kneading pins and the outer rotor. In general, the faster rotation of the inner rotor results in a better kneading

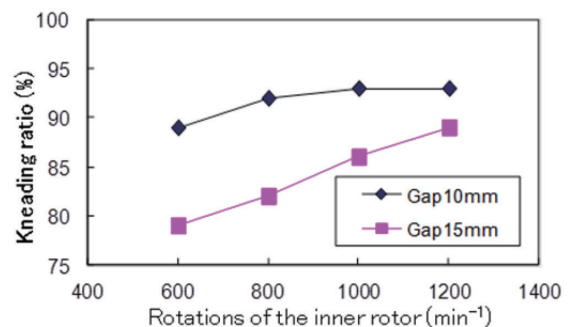

Fig. 6 Influence of the gap between the kneading pins and the outer rotor and the rotation of the inner rotor on the kneading ratio

ratio because it is guessed that both the shearing and the compressing force applied on the material increase as the rotation of the inner rotor becomes faster. With the smaller gap of 10 mm, the kneading ratio of 93 % was obtained because of a similar reason. Fig. 7 shows the distance of the gap between the kneading pins and the outer rotor.

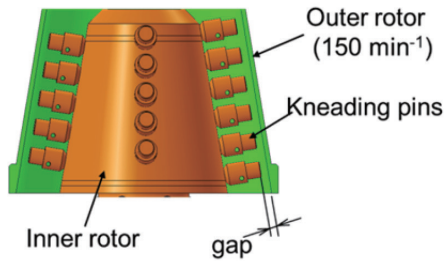

Fig. 7 Gap between the kneading pin and the outer rotor

4. FEATURES OF THE REFRACTORY MATERIALS FOR QMS

To obtain excellent durability of the applied material in hot service, the refractory materials for QMS have been developed pursuing the targets:

- 1) the application of a small amount of water and
- 2) a tight adhesion on the targeted spot.

Fig. 8 shows the quality map of the materials applied with the QMS method among various application methods of monolithic refractories. Table 1 shows typical properties of the material for the QMS in comparison with the material for conventional wet-gunning.

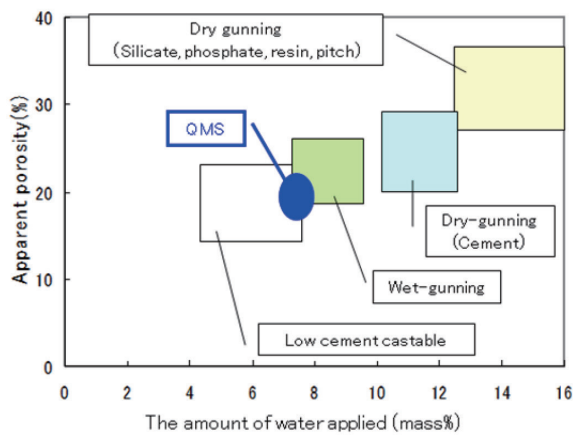

Fig. 8 The quality map in the obtained apparent porosity comparing various application methods of monolithic refractory materials

There is generally a tight connection between the amount of water applied and the density of the gunned material. During application, therefore, minimizing the amount of water is pursued to obtain a gunned material as dense as possible. Using the QMS method, it is determined that the applied material body shows excellent quality, which is equivalent to or better than the quality obtained by using the wet-gunning method.

Table 1 Typical properties of materials applied in QMS and wet-gunning

Installation method	QMS	Wet-gunning
Chemical composition/%	Al ₂ O ₃	82
	MgO	12
Apparent porosity/%	110°C×24h	21.4
	1500°C×3h	26.0
Bulk density/g/cm ³	110°C×24h	2.93
	1500°C×3h	2.74
Modulus of rupture/MPa	110°C×24h	5.1
	1500°C×3h	25.0
Permanent linear change/%	1500°C×3h	+1.36
	1500°C×12h	+1.38
		+0.35
Amount of water/mass%	7.7	8.8

5. AUTOMATIC CONTROL OF REPAIR WORK

In the QMS method, the kneading and projecting device is positioned and operated with well-combined mechanical motions (elevating, turning and tilting) in order to shape the material body with the required thickness at the targeted spot. Fig. 10 shows an exemplification of the combined effects of mechanical rotating velocity (in inverter frequency Hz of the power driving the motor) and elevating pitch (in mm) to obtain the required thickness (in mm) of the material body. Referring to appropriate combination patterns, the operational parameters are set to perform automatic mechanical motions to achieve the targeted repair.

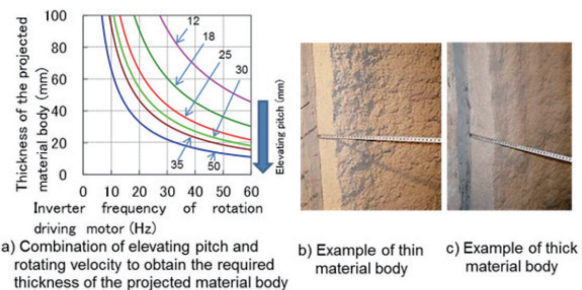

Fig. 10 An exemplified combination of mechanical parameters for automatic repair thickness control

6. DURABILITY OF THE MATERIAL APPLIED WITH THE QMS METHOD IN HOT LADLES

The QMS method has been employed recently in repairing steel ladles. Fig. 11 shows the steel ladle treated with the QMS method and Fig. 12 gives the actual durability result of the side-wall of the steel ladle. The actual result reached was 1.2 times the value obtained with conventional wet-gunning. With the remarkable durability of the gunned material, the QMS method has been contributing to a more stable and reliable performance in the service life of steel ladles.

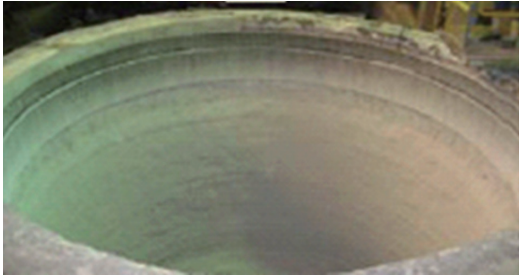

Fig. 11 Steel ladle side wall after treatment with the QMS method

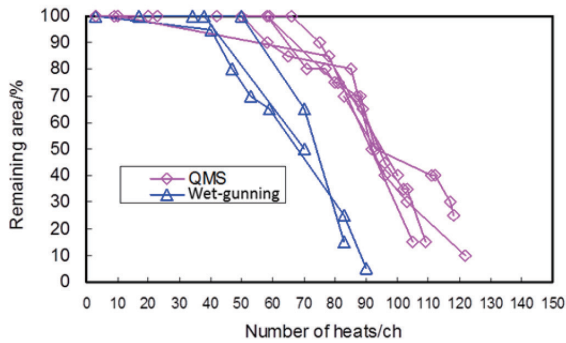

Fig. 12 The difference in durability of steel ladle linings between the QMS method and conventional wet-gunning

7. THE AUTOMATIC REPAIR EQUIPMENT FOR STEEL LADLES

Fig. 13 shows a sketch of the automatic repair equipment for steel ladles as an example of the application of the QMS method. The equipment was introduced to the steel plant of Nippon Steel & Sumitomo Metal Corp. Oita works. For a treatment, the entirety of the equipment is transported and positioned on a steel ladle. It consists of

- 1) the constant feeding device of refractory material, water and compressed air to convey the dry material,
- 2) the position control device for elevating, turning and tilting of the kneading and projecting device and
- 3) the steel frame to support the equipment.

The dry refractory material is fed constantly at a specified flow rate from the material tank, which is equipped with a load cell, and is conveyed in compressed air.

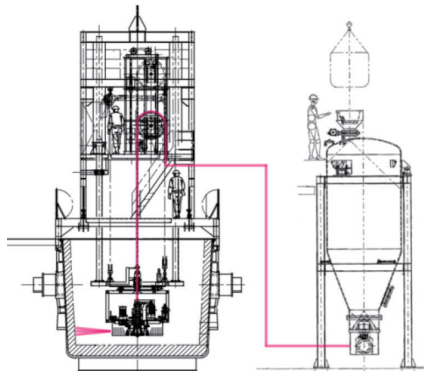

Fig. 13 The automatic repair equipment for steel ladles

The kneading and projecting device, hung on the steel frame, is mechanically operated with the sequentially programmed motion of elevating, turning and tilting to accomplish the targeted automatic repairing.

8. CONCLUSIONS

The advantages of the QMS method can be itemized as follows:

- 1) The repair work is as easy and simple as that of the dry-gunning method. The applied material shows excellent durability due to its sufficiently dense microstructure.
- 2) During gunning work there is little dust formation and rebounding and, therefore, a clean atmosphere is obtained at the repairing site.
- 3) The automatic control system equalizes the thickness of the layer of gunned material, which is effective to avoid individual variations in the repairing work.
- 4) The QMS method, as described above, is adopted properly and successfully in the steel works of Nippon Steel & Sumitomo Metal Corp. contributing greatly to a stable and reliable operational performance of ladles and furnaces and to an improvement of the furnace repair works.

REFERENCE

- 1) Y. Mizuma, H. Ebisawa, H. Ohata, H. Tomono, T. Matsui, H. Otsubo, H. Takeuchi and M. Satou: UNITECR 2011 31-A-5 p. 4.